

## **Camera interface**

**RL-A15**

**Rear view camera input  
compatible with Mercedes Vito  
Audio15 system**

## Contents

### 1. Prior to installation

- 1.1. Delivery contents
- 1.2. Check compatibility of vehicle and accessories
- 1.3. Setting the DIP-switches of the CAN-Box RLC-TV515
- 1.4. Pin-assignments

### 2. Connection schema

### 3. Installation

- 3.1. Interconnecting CAN-box, harness and factory navigation monitor
- 3.2. Connection to rear-view camera

### 4. Coding of the rear-view camera

- 4.1. Rear-view camera coding
- 4.2. Rear-view camera decoding

### 5. Speed related rear view camera shut down

### 6. Specifications

### 7. Technical support

## Legal Information

By law, watching moving pictures while driving is prohibited, the driver must not be distracted. We do not accept any liability for material damage or personal injury resulting, directly or indirectly, from installation or operation of this product. This product should only be used while standing or to display fixed menus or rear-view-camera video when the vehicle is moving, for example the MP3 menu for DVD upgrades.

Changes/updates of the vehicle's software can cause malfunctions of the interface. We offer free software-updates for our interfaces for one year after purchase. To receive a free update, the interface must be sent in at own cost. Labor cost for and other expenses involved with the software-updates will not be refunded.

## 1. Prior to installation

Read the manual prior to installation. Technical knowledge is necessary for installation. The place of installation must be free of moisture and away from heat sources.

### 1.1. Delivery contents

Take down the SW-version and HW-version of the interface boxes, and store this manual for support purposes.

CAN-box RLC-TV515  
HW \_\_\_\_\_ SW \_\_\_\_\_



Adapter  
CAB-TVAS20A

Harness  
TV-NTG2

### 1.2. Check compatibility of vehicle and accessories

#### Requirements

Vehicle Mercedes Vito (W447)

Navigation Audio15

#### Limitations

After-market rear-view camera Only compatible with NTSC-cameras.

## 1.3. Setting the DIP switches of the CAN-box RLC-TV515

Vehicle/ navigation	DIP 1	DIP 2	DIP 3	DIP 4	DIP 5	DIP 6
Camera coding	ON	OFF	OFF	OFF	OFF	ON
Camera decoding	OFF	OFF	OFF	OFF	OFF	ON

**Note:** DIP switch functions of the RLC-TV515

DIP 1 – Camera coding

DIP 2 – Speed related rear view camera shut down

DIP 3 – no function

DIP 4 – no function

DIP 5 – CAN-bus termination resistor on the vehicle side

DIP 6 – CAN-bus termination resistor on the head-unit side

## 1.4. Pin-assignments

### Pin-assignment factory connector

Assignment	Pin No.
+12V battery	Pin 15
Ground	Pin 12
CAN-low	Pin 9
CAN-high	Pin 11

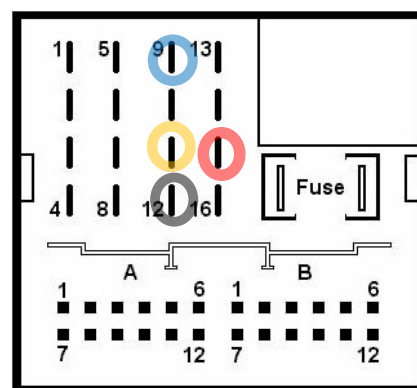

**No liability for vehicle wire colors and pin definition! Possible changes by the vehicle manufacturer. The given information must be verified by the installer.**

### Pin-assignment of the CAN-Box RLC-TV515 (Molex 8pin)

Cable colour	Pin-No.	Assignment
● Yellow	Pin 4	CAN-HIGH – connection to the head-unit
● Blue	Pin 3	CAN-LOW – connection to the head-unit
●● Yellow/Black	Pin 8	CAN-HIGH – connection to the vehicle
●● Blue/Black	Pin 7	CAN-LOW – connection to the vehicle
● Red	Pin 1	+12V permanent
● Black	Pin 5	Ground
● Green	Pin 6	No function
● White	Pin 2	+12V rear view camera (max. 400mA)

## 2. Connection schema

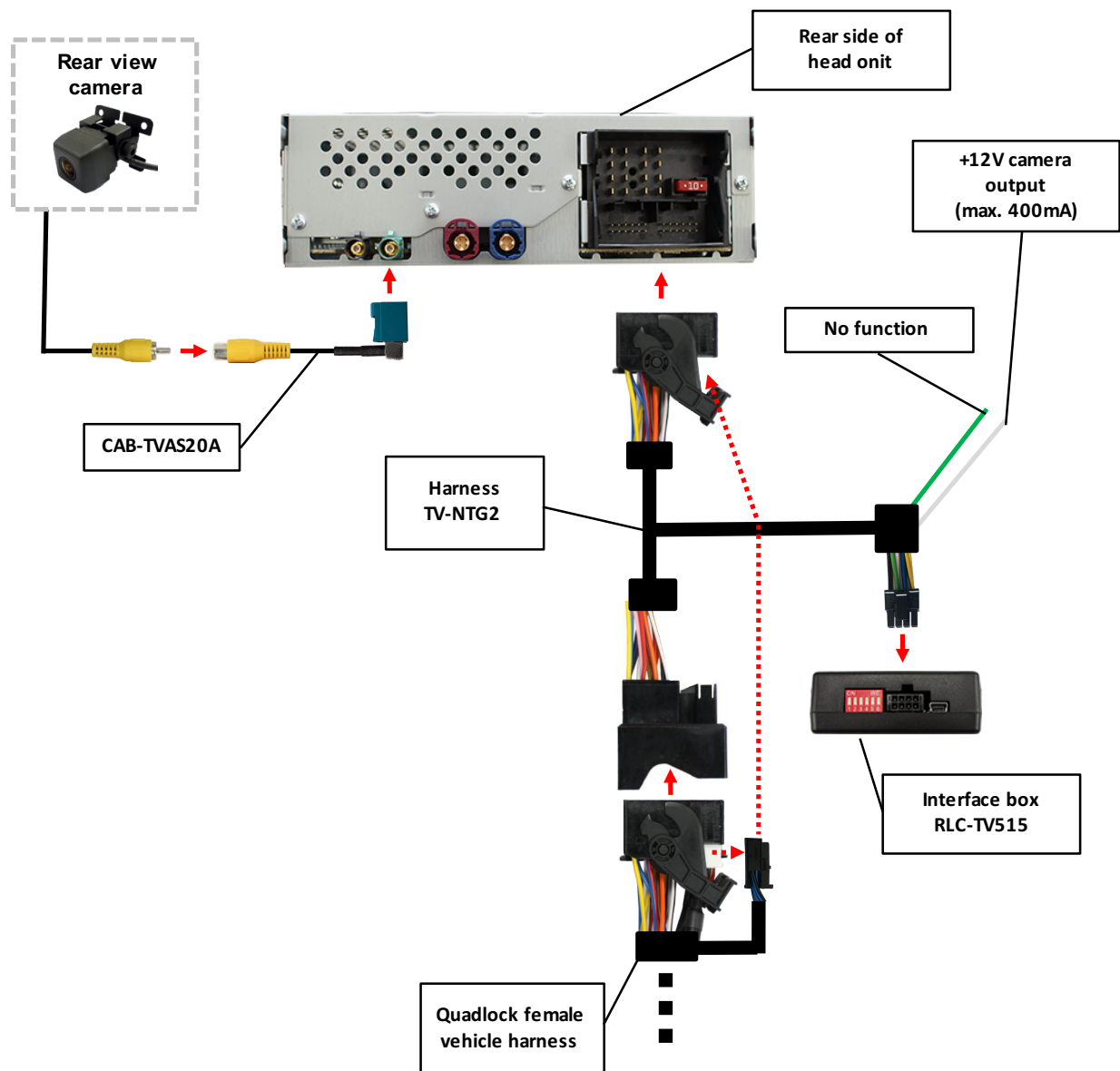

## 3. Installation

**Switch off ignition and disconnect the vehicle's battery! If according to factory rules disconnecting the battery has to be avoided, it is usually sufficient to put the vehicle in sleep-mode. In case the sleep-mode does not show success, disconnect the battery with a resistor lead.**

Place of installation is on rear of the head unit.

### 3.1. Interconnecting CAN-Box, harness and factory head unit

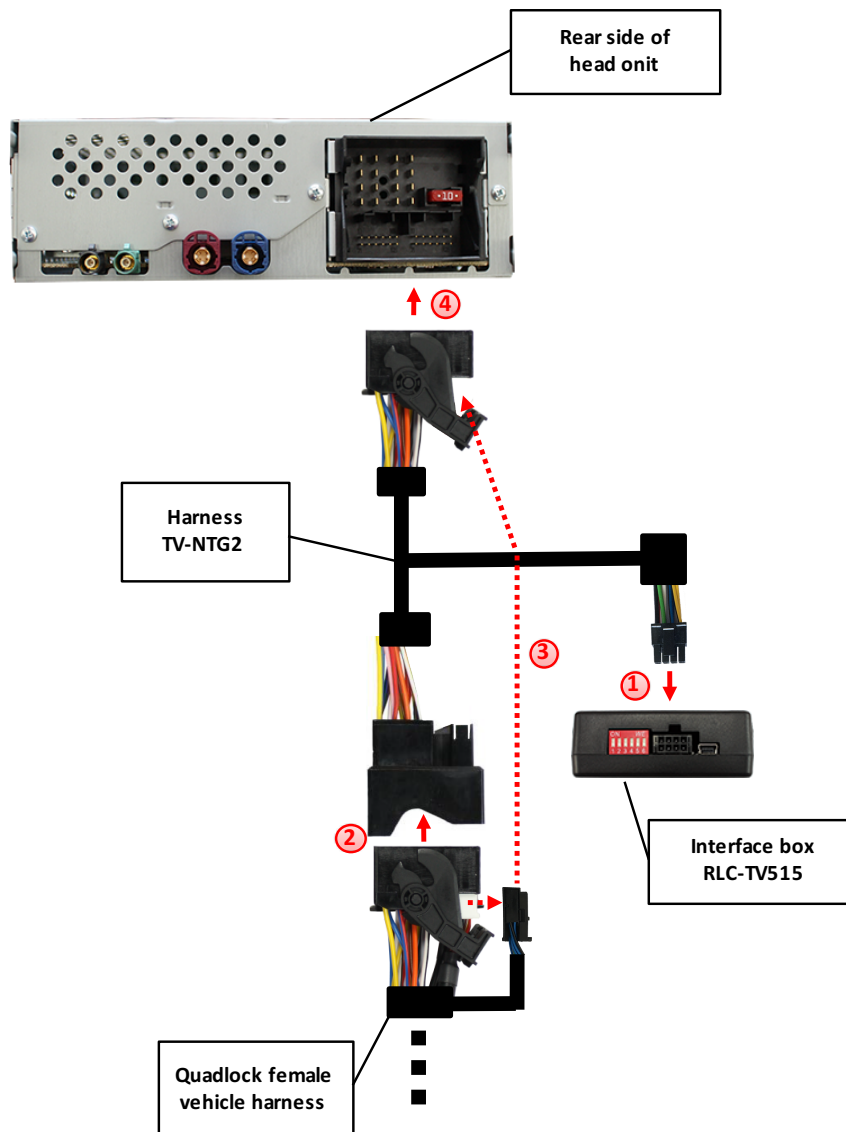

- 1 Connect female 8pin Molex connector of harness TV-NTG2 to male 8pin Molex connector of CAN-box RLC-TV515.
- 2 Remove the female Quadlock connector of the vehicle harness from the rear of the head unit and connect it to the male Quadlock connector of harness TV-NTG2.

- 3 Remove the 12pin Quadlock plug inserts from the female Quadlock connector of the vehicle harness and insert them into the female Quadlock connector of harness TV-NTG2 at the same position.
- 4 Connect female Quadlock connector of harness TV-NTG2 to the male Quadlock connector of the head unit.

**Note:** The loose green cable is not required and must be isolated.

### 3.2. Connections to rear-view camera

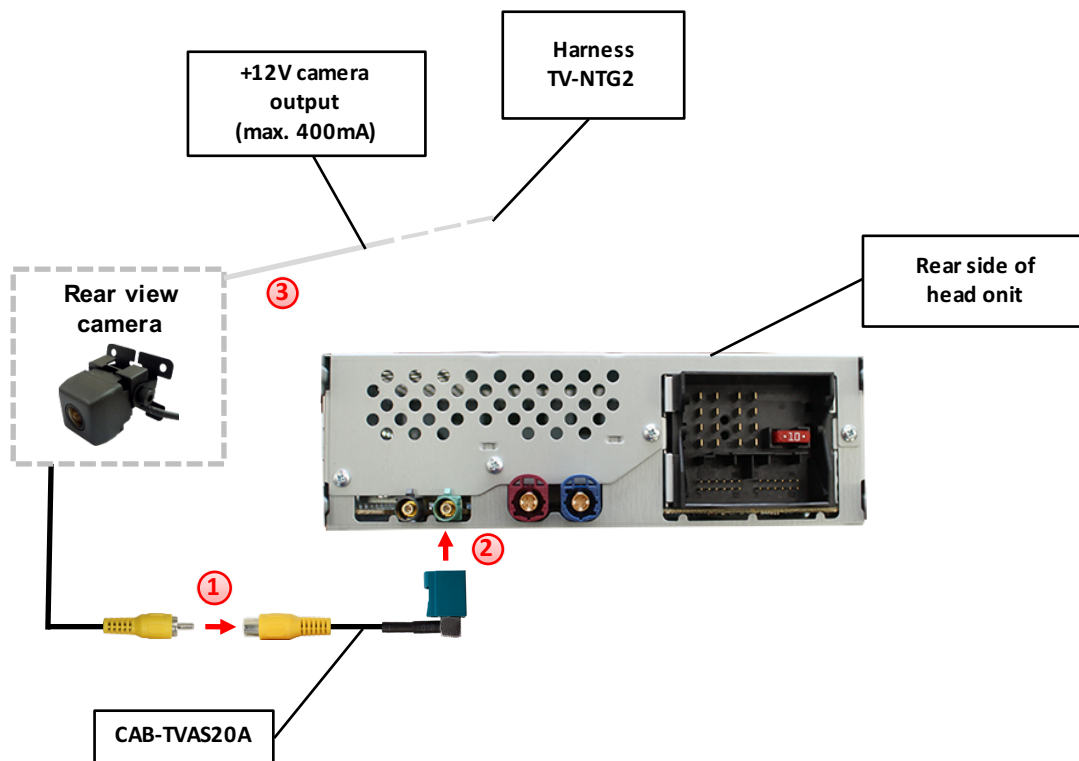

- 1 Connect the video RCA of the rear-view camera to the female RCA connector of adapter CAB-TVAS20A.
- 2 Connect the Fakra socket of adapter CAB-TVAS20A to the green Fakra connector on the rear of the head unit.
- 3 Connect the white cable of harness TV-NTG2 to the camera power supply (+12V, max 400mA). The white cable gets power when reverse gear is engaged. By leaving the rear camera level the power is switch off again

**Note:** Only compatible with NTSC-cameras.



## 4. Coding of the rear-view camera

### 4.1. Rear-view camera coding

1. Set DIP switch „1“ and „6“ to „ON“ (DIP 2,3,4,5 = OFF)
2. Turn ignition on (ignition position 2, for vehicles with automatic transmission start engine)
3. Wait until the Audio15 device has booted
4. Insert reverse gear („Diag“ appears on the screen and after a short time, the Audio15 device goes off)
5. Turn on the Audio15 device manually (press ON button)
6. The coding process is now complete

Note: When after the coding process the camera function is still not activated (red LED on the interface remains off), then additionally the ignition must be switched off and the vehicle must be locked for approx. 5 min.

### 4.2. Rear-view camera decoding

1. Set DIP switch „6“ to „ON“, „1“ to OFF (DIP 1,2,3,4,5 = OFF)
2. Turn ignition on (ignition position 2, for vehicles with automatic transmission start engine)
3. Wait until the Audio15 device has booted
4. Insert reverse gear („Diag“ appears on the screen and after a short time, the Audio15 device goes off)
5. Turn on the Audio15 device manually (press ON button)
6. The decoding process is now complete

#### LED information:

LED	Status	Explication
Blue	Lights	CAN bus communication OK
	Flashes	CAN bus search
Red	Lights	Rear-view camera is coded
	Off	Rear-view camera is not coded

**Note:** After the first use on a vehicle, the RL-A15 interface is personalized to this vehicle and can be used unlimited times to code or reverse coding on this vehicle.

## 5. Speed related rear view camera shut down

DIP 1	DIP 2	DIP 3	DIP 4	DIP 5	DIP 6
ON	ON	OFF	OFF	OFF	ON

**DIP 2 switch „ON“\***: Rear view camera automatically switches off at 20 km/h

**DIP 2 switch „OFF“**: Rear view camera switch off when reverse gear is disengaged

**\*Note:** Rear view camera can also be manually switched off via the Audio15 system

## 6. Specifications

Operation voltage	10.5 – 14.8V
Stand-by power drain	<2mA
Operation power drain	~60mA
Power consumption	~0,08W
Temperature range	-30°C to +80°C
Weight	44g
Measurements (box only) W x H x D	70 x 20 x 47 mm/ 76 x 27 x 54 mm

## 7. Technical support

**CAS GmbH**  
**manufacturer/distribution**  
In den Fuchslöchern 3  
D-67240 Bobenheim-Roxheim

email [support@casgermany.com](mailto:support@casgermany.com)

**Legal disclaimer:** Mentioned company and trademarks, as well as product names/codes are registered trademarks ® of their corresponding legal owners.